

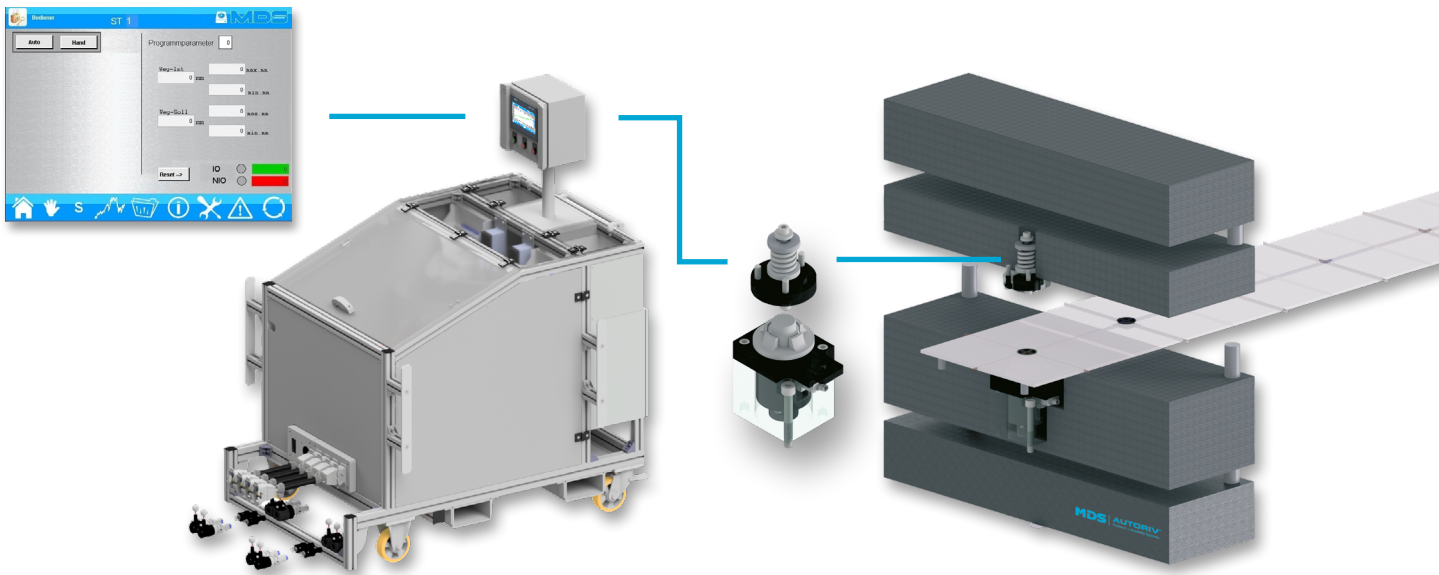

# AUTORIV A100

- ▶ Presence and error detection for bushings
- ▶ For a fully automatic assembly in the tool



- ▶ Maximum safety in the overall process
- ▶ Real-time presence and error detection
- ▶ Continuous and safe production
- ▶ Precise path recording and evaluation
- ▶ Evaluation of each individual insertion process possible
- ▶ OK / NOK shown on display
- ▶ Space-saving, compact design



A 100	GB	FTP

## AUTORIV A100: Presence and error detection for bushings

- ▶ In **AUTORIV A100** insertion units, a „fastener in insertion position“ query is made via the integrated sensor system in the installed insertion head.
- ▶ An optional module for presence and error detection is also available. An OK or NOK message is issued in a downstream test module.

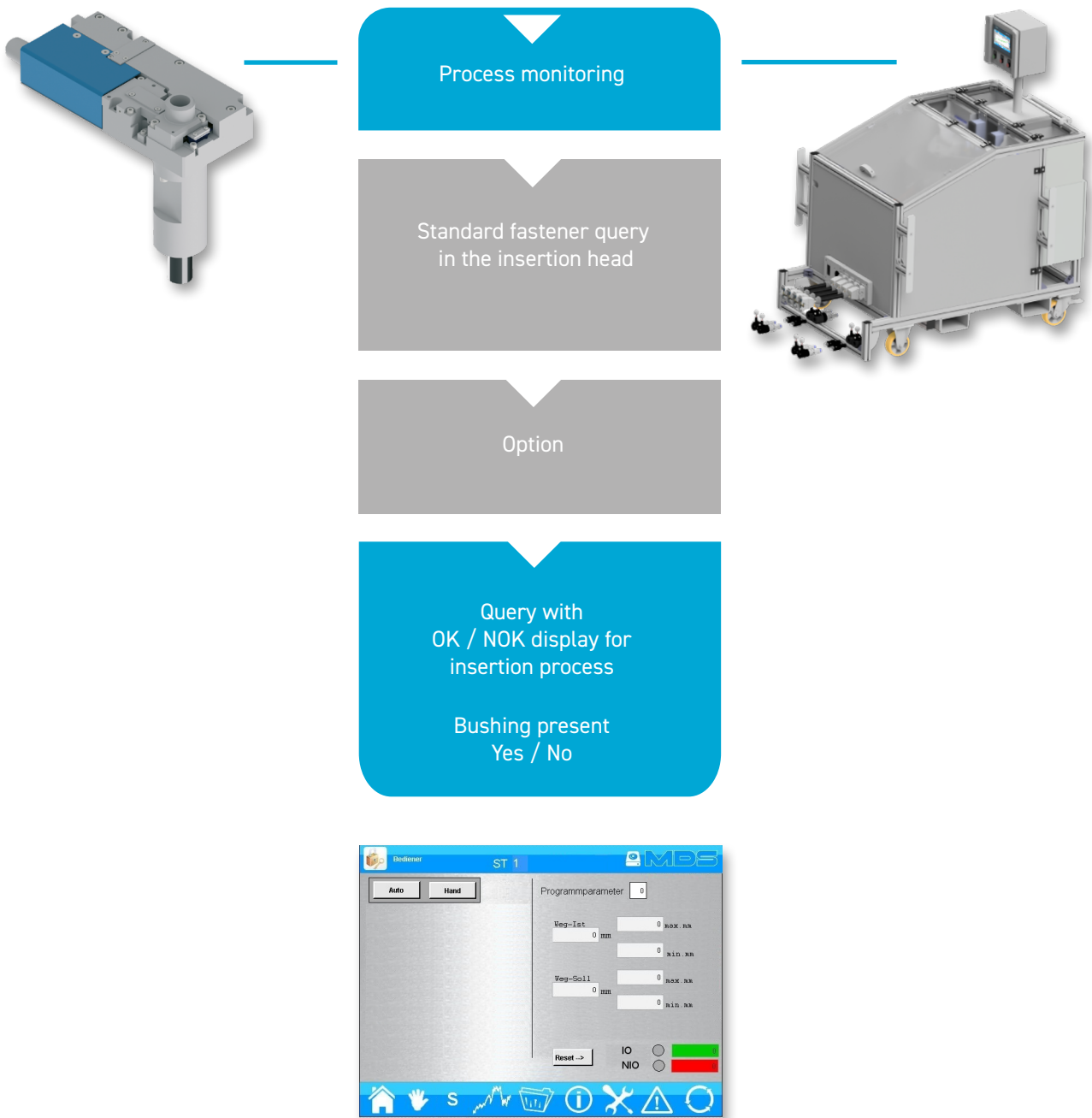

## AUTORIV: Real-time presence and error detection with the PAB module

- ▶ Process evaluation is also available as an option. It monitors the pressing process and provides an OK/NOK message and a yes/no message to indicate the presence of the bushing.
- ▶ The PAB module is designed to be mounted in a press tool, such as on a base plate or pressure pad.
- ▶ A data line transfers the process data to the controller.
- ▶ The process data can optionally be visualized graphically and can be edited in the controller.

### PAB module for presence and error detection

### Tool with integrated PAB module for bushings

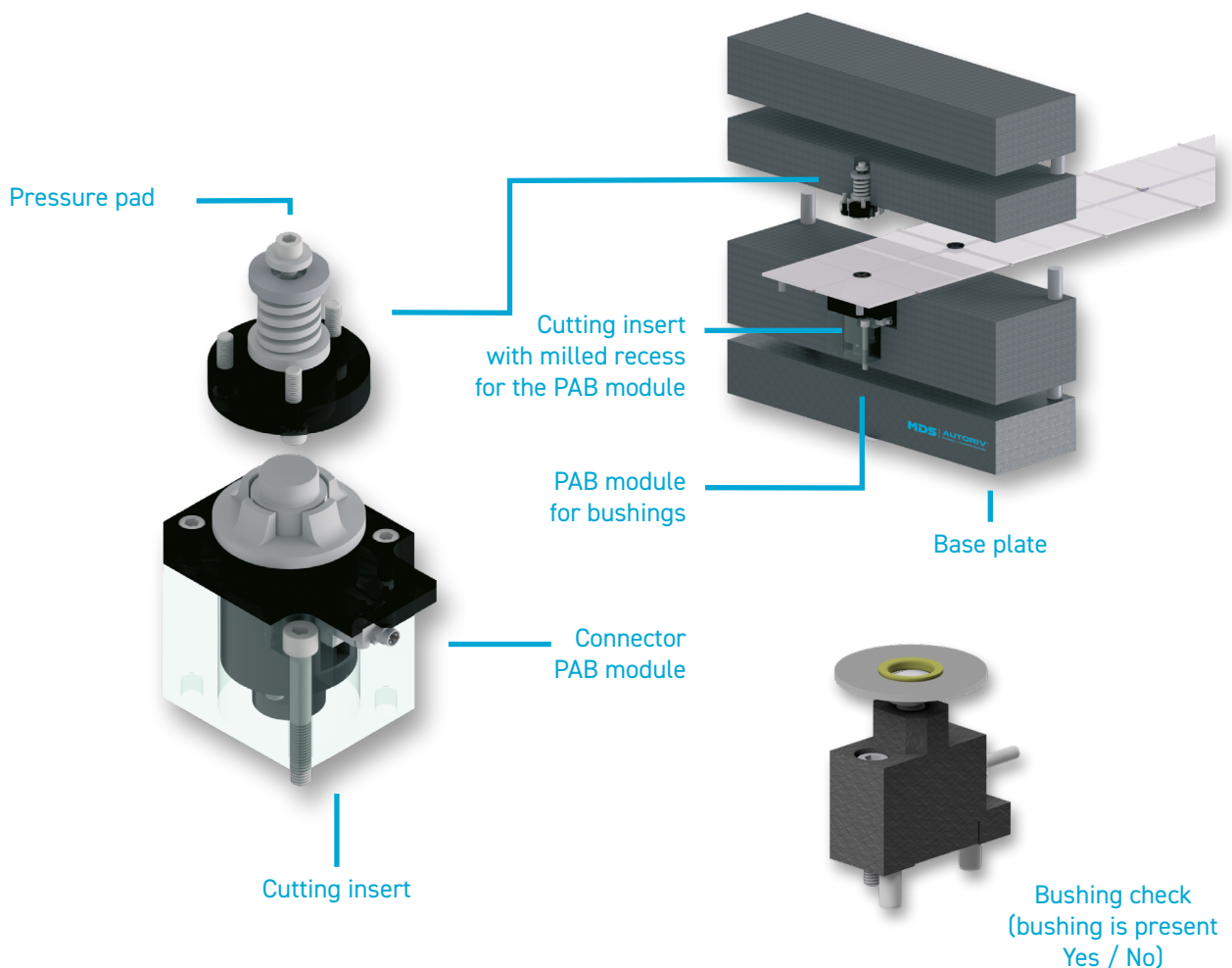

In addition, **AUTORIV**<sup>®</sup> offers further versions for customer-specific applications.

## AUTORIV: About Our Company

MDS Maschinen- und Werkzeugbau GmbH & Co. KG has now become MDS Germany GmbH and joined the PennEngineering® Group.

This acquisition represents a key milestone in our long-term global growth strategy, enabling us to expand our product portfolio and offer an even wider range of tailored solutions and services.

Our customers are from the sheet metal processing industry, mostly from the automotive sector. We supply automotive manufacturers (OEMs), Tier1, smaller tiers and suppliers.

We are also present with our production automation systems in the industries of trucks, white goods, heating, ventilation and air conditioning systems (HVAC), electronics, and agricultural machinery. Our main markets are Europe, North and Central America.

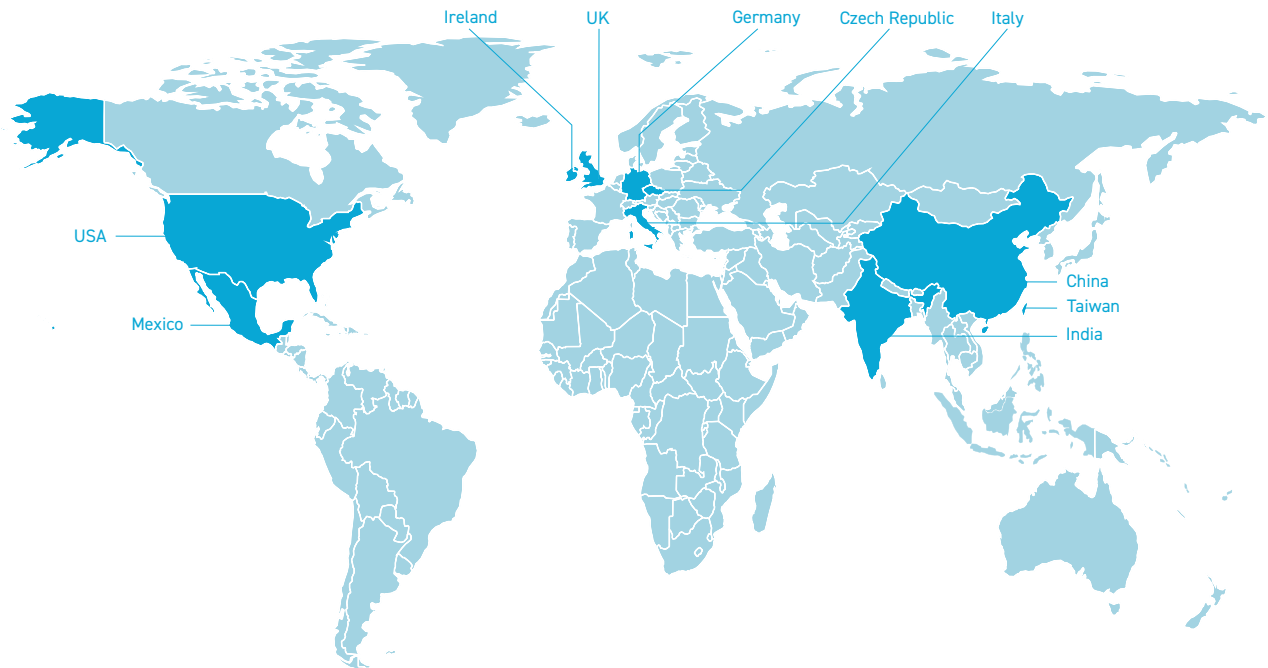

## AUTORIV: A Brand of the MDS Fastening Systems

**MDS Germany GmbH**  
 Ditthornstraße 22  
 93055 Regensburg  
 GERMANY

Phone: +49 941-6042-210  
 Fax: +49 941-6042-162  
 E-Mail: [vertrieb@mds-r.de](mailto:vertrieb@mds-r.de)  
 Web: [www.autoriv.com](http://www.autoriv.com)

**MDS Fastening Systems, LLC**  
 P.O. Box 417  
 Washington, MI 48094  
 USA

E-Mail: [inquiries@mds-fs.com](mailto:inquiries@mds-fs.com)  
 Web: [www.autoriv.com](http://www.autoriv.com)